

TANKAGE | VENTING GAUGE HATCHES

## SERIES 4000 MARSH HAWK TRV



### Features

- Premium deep-set gauge hatch with integral pressure & vacuum relief offers superior performance in normal and cold conditions.
- Reliable, bubble-tight sealing with standard FKM (Viton) seal and stainless steel spring.
- Field adjustable pressure settings, from 2 ozsi to 32 ozsi.
- Manual relief, Inconel trim, alternative seals and various coatings optionally available.

## FEATURES

### Deep-set venting gauge hatch

- The Series 4000 Marsh Hawk TRV offers tank access combined with pressure and vacuum relief in a deep-set design.
- Situating valve seats below the tank roof permits latent heat from the product to keep the seals ice-free.

### Reliable, bubble-tight sealing

- The Series 4000 has class-leading seal performance as compared to any other premium or economy venting gauge hatch currently available.
- Improved sealing performance eliminates flutter and periodic small-scale venting which can cause frost closure in competitor top-mount hatches.



False-colour cutaway of a Series 4000 Marsh Hawk TRV showing the deep-set seal (orange), pressure spacers (blue) and springs (red).

### Variety of pressure settings

- The Series 4000 Marsh Hawk pressure relief is adjustable between 2 ozsi and 16 ozsi in 2 ozsi increments.
- The optional double-weight spring allows relief pressure between 18 and 32 ozsi, in 2 ozsi increments.
- 1 ozsi increments optionally available.
- Vacuum relief is fixed at 0.4 ozsi.

### Suitable for Sour Service

- The Series 4000 is ready for Sour Service out of the box with FKM (Viton) seals and stainless springs.
- For more adverse applications, alternative seal and spring materials are available, along with hard anodization or fusion-bond epoxy coatings.

## DIMENSIONS

	Dimension	Value	
		[in.]	[mm.]
Dmax	Body Diameter (max)	7.93	201
F	Flange Thickness	0.6	15.3
Fd	Flange Diameter	12.0	305
Hc	Height (Closed)	5.1	130
Ho	Height (Minimum to Open)	12.5	318
Hp	Height (Penetration in Tank)	9.2	234
Lo	Length (Hatch Open)	14.3	363
	Weight	28 lb	12.7 kg
B	Mounting Bolt Hole	9/16 min	15
ID	Minimum Cutout Diameter	7.98" min	203
BCD	Bolt Circle Diameter	10.38	264
	Bolt Quantity & Size	16 × 1/2-13UNC	

## SPECIFICATIONS

Function	Venting Gauge Hatch
Temperature Range <sup>1</sup>	-26°C to 204°C [-15°F to 400 °F] (FKM) -9°C to 230°C [16°F to 446°F] (FEPM) -18°C to 320°C [0°F to 600°F] (FFKM)
Pressure Relief Type	Direct-acting, Spring-loaded
Pressure Relief Range	2 to 32 ozsi
Vacuum Relief Range	0.4 ozsi fixed
Tank Connection	8" API (Fig 1 API 12F)

<sup>1</sup>Temperatures provided are continuous service temperatures for the indicated seal materials. See the short term extended service temperatures below in "Seal Materials and Configuration" section.

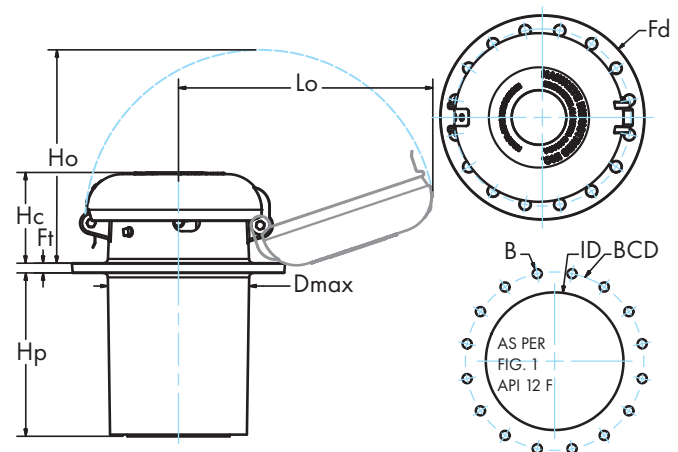

# FLOW CHARACTERISTIC

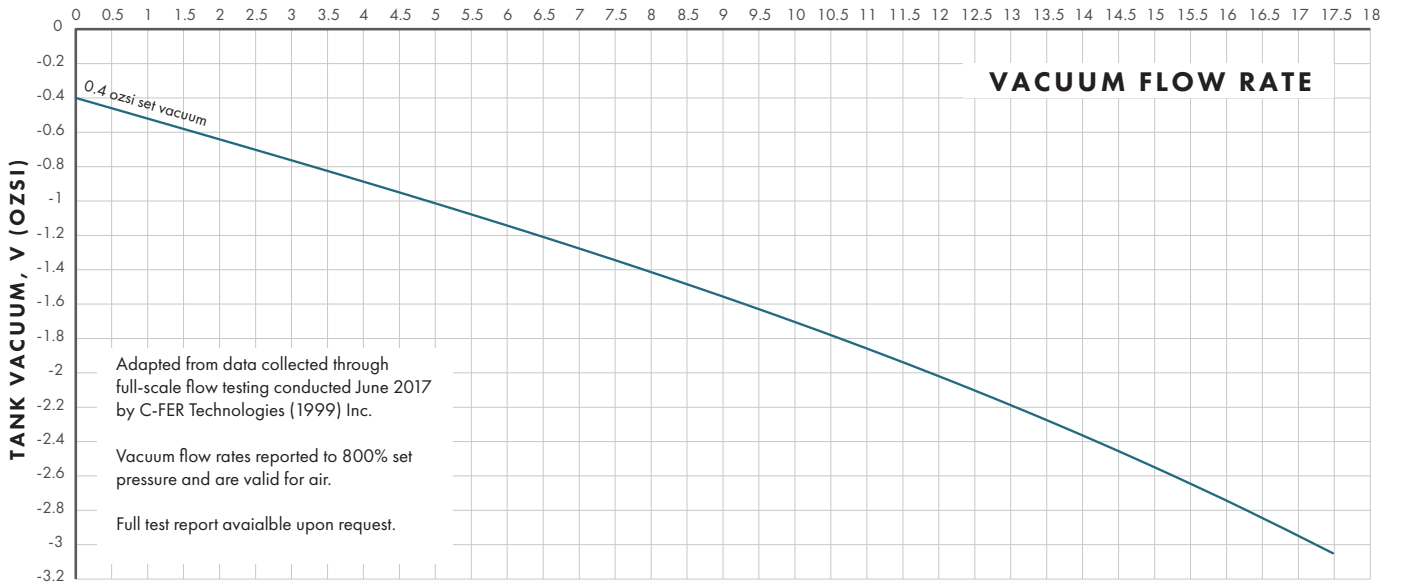
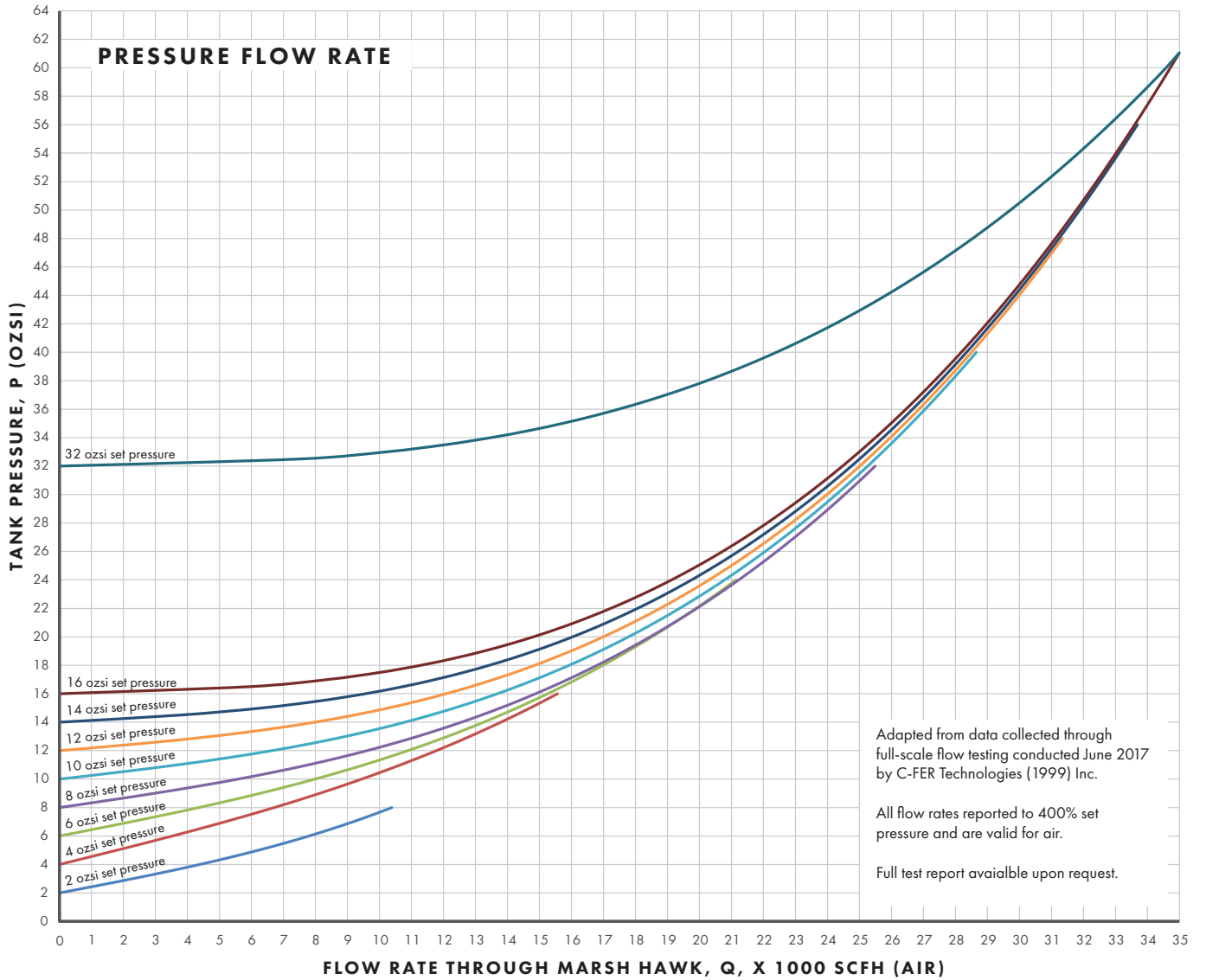

## OPTIONS AND ACCESSORIES

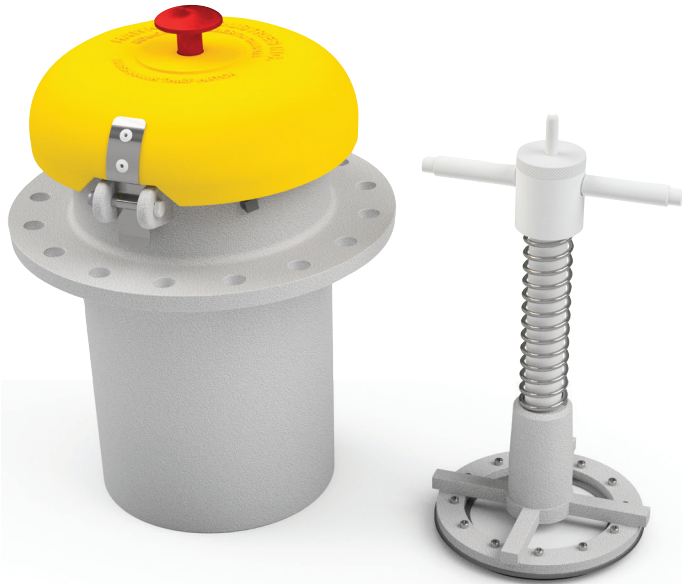

Series 4000 Marsh Hawk TRV With Manual Relief Option

### Hard Anodized (Type III)

For situations requiring improved corrosion resistance over the standard Marsh Hawk, a Hard Anodization option is available. This electrochemical process increases the thickness and durability of the ceramic-like natural aluminum oxide layer.

All aluminum components are anodized to meet MIL-A-862F Type III Engineering Hardcoat. The anodization slightly darkens the cast components and imparts a slight bronze tinge to the machined components.

Anodization improved performance in moderate brines, as well as acetic, boric and nitric acid. For prolonged exposure to concentrated brines, or strong mineral acids, consider the severe service coating.



Series 4000 Marsh Hawk TRV with Severe Service Coating

### Manual Relief

The manual relief option allows an operator to manually activate the vent.

Pressing the hatch cover's large red button on the actuates the vacuum pallet, relieving pressure in the tank to allow safe removal of the spider cage assembly for tank gauging or hatch maintenance. The button and actuating poppet are supported independently of the vacuum disc, and do not interfere with normal relieving operation.

Typical Manual Relief Operating Force			
Set Pressure (oszi)	Actuation Force (lbf)	Set Pressure (oszi)	Actuation Force (lbf)
4	5	12	14
6	7	16	19
8	9	32	38

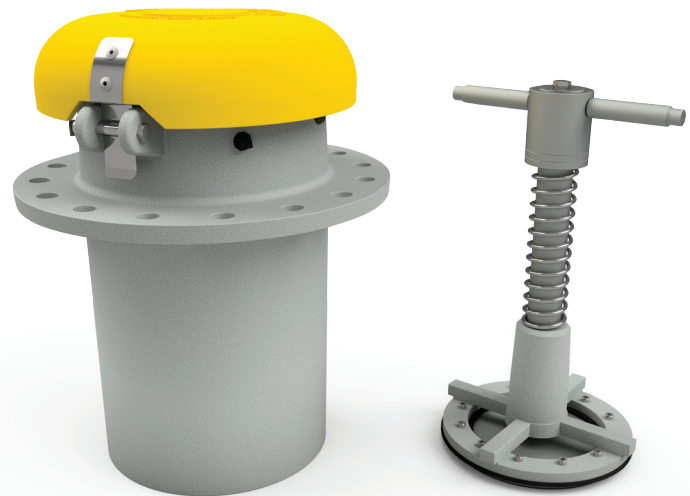

Series 4000 Marsh Hawk TRV with Hard Anodization

### Severe Service Coating

For situations demanding the highest corrosion resistance, consider the Severe Service coating.

The body of the Marsh Hawk is coated with a red Fusion Bond Epoxy (FBE) for resistance to strong mineral acids, (including sulphuric and hydrochloric acids,) high-chloride ion solutions (including aluminum chloride, potassium chloride and brine) as well as many other petrochemicals.

The Marsh Hawk internals are coated in a proprietary black PFA (TEFLON) providing the same excellent fluoropolymer chemical resistance.



## OPTIONS AND ACCESSORIES (CONTINUED)

### De-icing System

Allows direct injection of a seal-appropriate de-icing solution onto the Marsh Hawk internals from ground level. Includes spray nozzle and hose assembly.

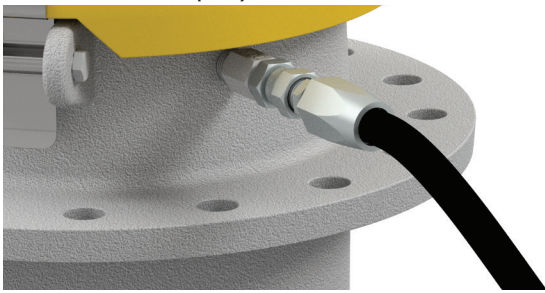

### Mesh Hat

A formed 10 Mesh 304 stainless steel cover to keep insects and debris from interfering with the Marsh Hawk internals.

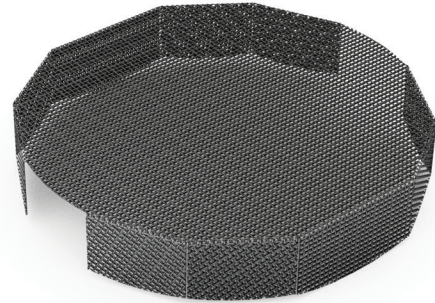

## SEAL CONFIGURATION AND MATERIALS

The Series 4000 Marsh Hawk combines the pressure and vacuum valve in an innovative design that requires only one shared gasket.

To improve valve sealing performance, gaskets are factory coated with a pliable silane-based sealant. An optional oil-based sealant for use in sour gas applications is also available. Both sealants are available in small packages for maintenance and reapplication.

Hawkeye offers three material options for the pressure / vacuum seal, beyond the standard FKM (Viton®) seal.

- For applications where sealing is the first priority and the vent is not expected to operate often and has low set pressures (under 4 ozsi), eFKM (Sponge Viton®) can be supplied.
- For higher temperature, minimally freezing conditions and acid service FEPM (Aflas®) is available.
- For extreme applications FFKM (Kalrez®) is also available.

The use of EPDM seals in any Hawkeye vent is contraindicated due to its unsuitability in common petrochemical applications.

Hawkeye does not offer or recommend using solid fluoropolymer (PTFE, PFA, FEP, etc.), nor expanded fluoropolymer (GORE-Tex®) as a gasket material and any venting device. Although the material may be chemically suitable, the harder crystalline polymer structure of these materials impedes sealing at the typically low interfacial pressures found in the Marsh Hawk, as well as other low-pressure (i.e. <15 psi) vents.

GENERAL FLUOROELASTOMER CHEMICAL COMPATIBILITY<sup>1</sup>

	FKM / VITON	FEPM / AFLAS	FFKM / KALREZ	EPDM <sup>2</sup>
BTEX	Red	Red	Yellow	Red
AMINES	Red	Green	Yellow	Red
CRUDE OIL	Green	Yellow	Green	Red
NATURAL GAS	Green	Green	Green	Red
HYDROCHLORIC ACID	Green	Green	Green	Red
SULPHURIC ACID	Orange	Green	Green	Red
SOUR CRUDE OIL	Green	Green	Green	Red
SOUR NATURAL GAS	Green	Green	Green	Red

■ EXCELLENT   
 ■ GOOD   
 ■ FAIR   
 ■ UNSUITABLE

N.B. <sup>1</sup> THIS CHART IS FOR REFERENCE ONLY. ALTHOUGH HAWKEYE STRIVES TO ENSURE PRESENTED INFORMATION IS ACCURATE, A QUALIFIED PERSON SHOULD ENSURE THE SUITABILITY OF A SELECTED MATERIAL IN THE SPECIFIC CHEMICAL, TEMPERATURE AND PRESSURE CONTEXT OF THEIR APPLICATION.  
<sup>2</sup> SHOWN FOR COMPARISON PURPOSES ONLY, NOT AVAILABLE AS A SEAL MATERIAL ON HAWKEYE VENTS

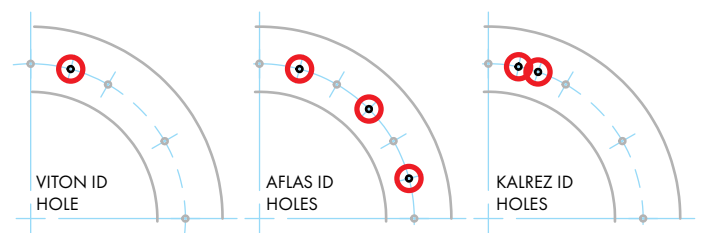
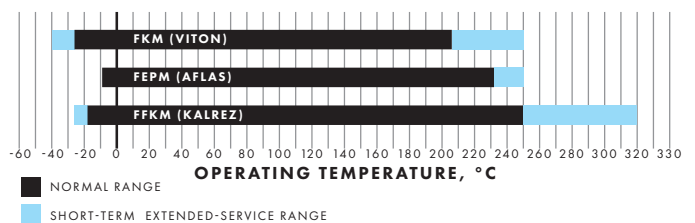

IDENTIFYING MARSH HAWK GASKET MATERIAL



## PARTS LIST &amp; MATERIALS OF CONSTRUCTION

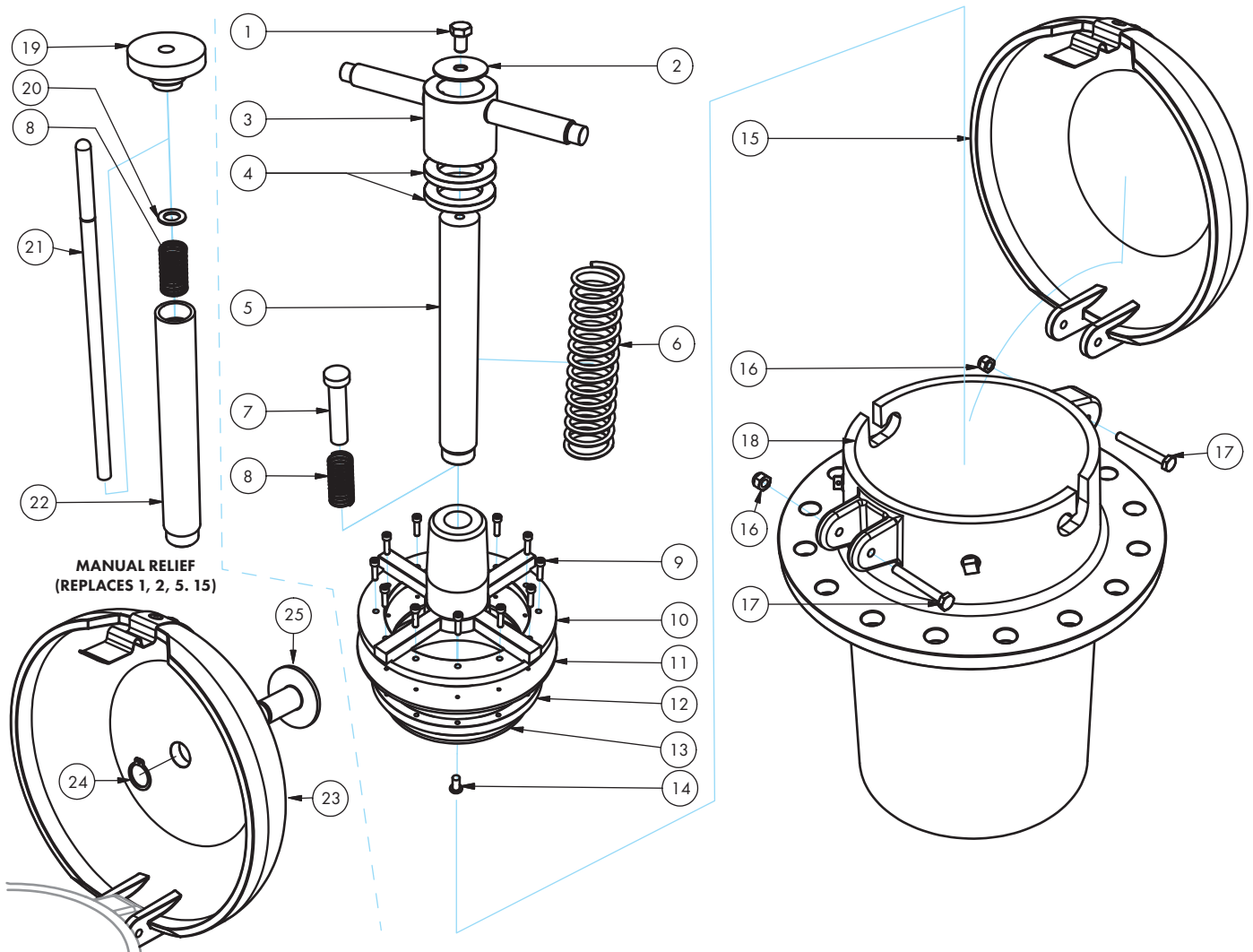

Item	Part Name	Std. Material	Opt. Material	Item	Part Name	Std. Material	Opt. Material
1	Pressure Guide Bolt	316 Stainless		15	Cover & Latch Assembly	356.2 Cast Aluminum	
2	Pressure Guide Washer	6061 Aluminum		16	1/4 NC Nylok Nut	316 Stainless	
3	Pressure Guide Handle	6061 Aluminum		17	1/4 NC Hinge Bolt	316 Stainless	
4	Pressure Setting washer	6061 Aluminum		18	Marsh Hawk Body	356.2 Cast Aluminum	
5	Pressure Guide	6061 Aluminum		19	Pressure Guide Cap	6061 Aluminum	
6	Pressure Guide Spring	302 Stainless	X750 Inconel	20	Manual Relief Poppet Retaining Ring	6061 Aluminum	
7	Vacuum Stem	6061 Aluminum		21	Manual Relief Poppet	6061 Aluminum	
8	Vacuum Stem Spring	302 Stainless	X750 Inconel	22	Pressure Guide for Manual Relief	6061 Aluminum	
9	Seal Retention Screw	316 Stainless		23	Cover & Latch Assembly for Manual Relief	356.2 Cast Aluminum	
10	Spider Cage	710.0 Cast Aluminum		24	Manual Relief Button Retaining Ring	316 Stainless	
11	Pressure + Vacuum Seal	FKM ( Viton)	FEPM (Aflas) FFKM (Kalrez)	25	Manual Relief Button	6061 Aluminum	
12	Cage Seal Retainer	6061 Aluminum					
13	Vacuum Plate	5052 Aluminum					
14	Vacuum Plate Bolt	316 Stainless					



## RISERS, SPOOLS AND PIPEAWAYS

Bolt-on risers account for the slope of the tank roof ensuring the Series 4000 Marsh Hawk sits level for trouble-free operation. Adapter spools allow installation of a Marsh Hawk or other 8" API 12B/F device onto an ANSI B16.5 flange or other API manway or tank opening. Pipe-aways allow the vapors exhausted from a Marsh Hawk to be collected a piped away. See the "Risers Spools & Pipe-aways" brochure for more information.

### 12:1 Bolt-on Hatch Riser

The most popular riser used with the Series 4000 Marsh Hawk, the HRP-8P-8P-4A, ensures a vertical gauge hatch orientation on a 12:1 sloped tank roof with an existing 8" API 12B/F connection.

HRP-8P-8P-4A 12:1 Riser Dimensions			
Dimension		Value	
		[in.]	[mm.]
Rh	Riser Height (max)	4.2	107
Rcmin	Minimum flange gap	2.5	63.5
P	Pitch	12:1	4.8°
Rd	Outside Diameter	12.0	305
Ri	Inside Diameter	8.0	203

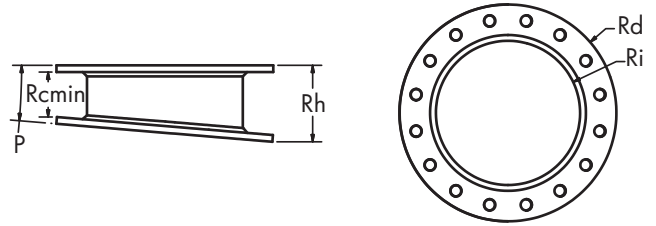

## VENT MARKING

The spider cage assembly of the Series 4000 Marsh Hawk is tagged with the initial factory configuration of the valve. As the relief pressure is field-adjustable, space is left on the tag to record future set pressures, should they change.

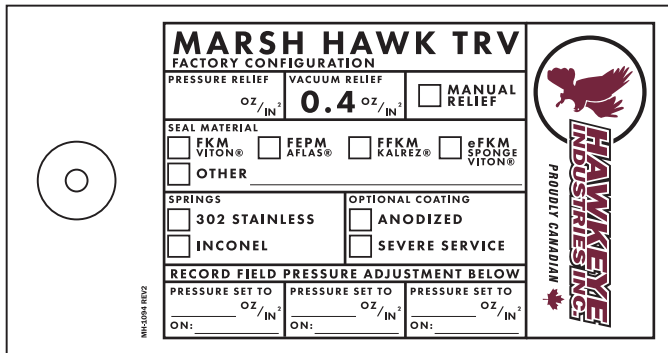

## PACKAGING

Series 4000 Marsh Hawks are shipped complete and boxed. In addition to the Marsh Hawk itself, the carton contains bolt kit(s), tank gasket(s) and installation instructions.

Weight is approximately 28 lb [12.7 kg].

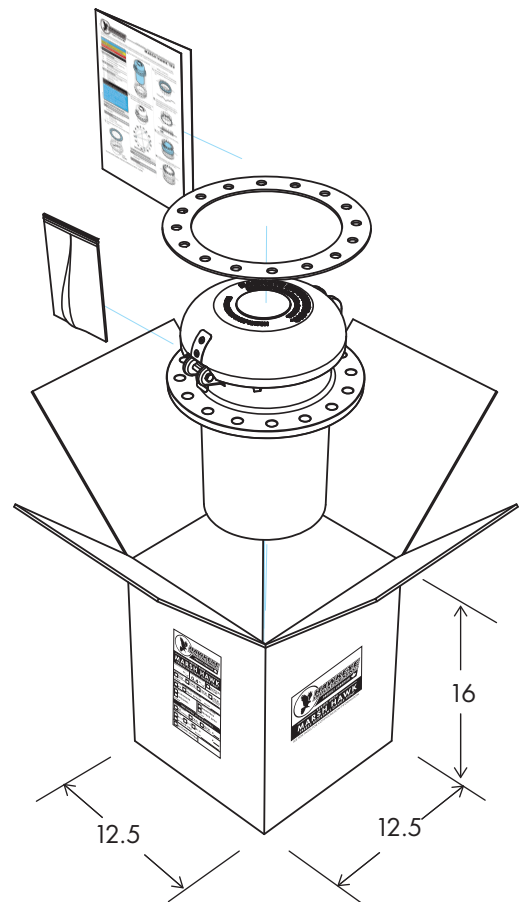

## PRESSURE TESTING

Series 4000 Marsh Hawks are tested prior to packaging to ensure pressure-tightness and relief setting accuracy. Items passing the quality control measures are marked with the label at right.



## CERTIFICATION

The pressure and vacuum relief settings of the Series 4000 Marsh Hawk can be factory certified at an additional expense. Certified hatches are accompanied by a certificate stating the relief pressure of the hatches.



## ORDERING INFORMATION

Standard Series 4000 Marsh Hawk configurations are stocked ready to ship. Other configurations are typically assemble-to-order and available in under two weeks. Configure your desired Series 4000 Marsh Hawk TRV using the part number legend below. Items in bold are standard items and have fastest lead times. All Series 4000 Marsh Hawks ship complete with a Gr. 5 Bolt kit and CR (Neoprene) Base gasket, both upgradable (see below). For project quantities, contact your Hawkeye sales rep for delivery schedules.

Pressure Relief Setting		Options			Accessories																																																										
MH - Sp Sp Sp		G - S C M			Bolting Kit																																																										
<table border="1"> <thead> <tr> <th colspan="2">Set Pressure</th> </tr> <tr> <th>Setting (ozsi)</th> <th>Flag</th> </tr> </thead> <tr><td>2</td><td>002</td></tr> <tr><td>3</td><td>003</td></tr> <tr><td>4</td><td>004</td></tr> <tr><td>5</td><td>005</td></tr> <tr><td>6</td><td>006</td></tr> <tr><td>:</td><td>:</td></tr> <tr><td>31</td><td>031</td></tr> <tr><td>32</td><td>032</td></tr> </table>		Set Pressure		Setting (ozsi)	Flag	2	002	3	003	4	004	5	005	6	006	:	:	31	031	32	032	<table border="1"> <thead> <tr> <th colspan="2">[G] Seal Material</th> </tr> <tr> <th>Material</th> <th>Flag</th> </tr> </thead> <tr><td><b>FKM (Viton)</b></td><td><b>V</b></td></tr> <tr><td>eFKM (Foam Viton)</td><td>F</td></tr> <tr><td>FEPM (AFLAS)</td><td>A</td></tr> <tr><td>FFKM (Kalrez)</td><td>K</td></tr> </table>		[G] Seal Material		Material	Flag	<b>FKM (Viton)</b>	<b>V</b>	eFKM (Foam Viton)	F	FEPM (AFLAS)	A	FFKM (Kalrez)	K	<table border="1"> <thead> <tr> <th colspan="2">[C] Coatings</th> </tr> <tr> <th>Coating Option</th> <th>Flag</th> </tr> </thead> <tr><td><b>None</b></td><td><b>0</b></td></tr> <tr><td>Anodize (Type III)</td><td>1</td></tr> <tr><td>Severe Service FBE</td><td>2</td></tr> </table>		[C] Coatings		Coating Option	Flag	<b>None</b>	<b>0</b>	Anodize (Type III)	1	Severe Service FBE	2	<table border="1"> <thead> <tr> <th colspan="2">[B] Bolt Grade</th> </tr> <tr> <th>Grade</th> <th>Flag</th> </tr> </thead> <tr><td><b>Gr. 5</b></td><td><b>57</b></td></tr> <tr><td>Gr. 8</td><td>58</td></tr> <tr><td>S.S</td><td>59</td></tr> <tr><td>Hybrid Hex</td><td>60</td></tr> </table>				[B] Bolt Grade		Grade	Flag	<b>Gr. 5</b>	<b>57</b>	Gr. 8	58	S.S	59	Hybrid Hex	60
Set Pressure																																																															
Setting (ozsi)	Flag																																																														
2	002																																																														
3	003																																																														
4	004																																																														
5	005																																																														
6	006																																																														
:	:																																																														
31	031																																																														
32	032																																																														
[G] Seal Material																																																															
Material	Flag																																																														
<b>FKM (Viton)</b>	<b>V</b>																																																														
eFKM (Foam Viton)	F																																																														
FEPM (AFLAS)	A																																																														
FFKM (Kalrez)	K																																																														
[C] Coatings																																																															
Coating Option	Flag																																																														
<b>None</b>	<b>0</b>																																																														
Anodize (Type III)	1																																																														
Severe Service FBE	2																																																														
[B] Bolt Grade																																																															
Grade	Flag																																																														
<b>Gr. 5</b>	<b>57</b>																																																														
Gr. 8	58																																																														
S.S	59																																																														
Hybrid Hex	60																																																														
		<table border="1"> <thead> <tr> <th colspan="2">[S] Spring Material</th> </tr> <tr> <th>Material</th> <th>Flag</th> </tr> </thead> <tr><td><b>Stainless Steel</b></td><td><b>0</b></td></tr> <tr><td>Inconel</td><td>1</td></tr> </table>		[S] Spring Material		Material	Flag	<b>Stainless Steel</b>	<b>0</b>	Inconel	1	<table border="1"> <thead> <tr> <th colspan="2">[M] Manual Relief</th> </tr> <tr> <th>Relief Option</th> <th>Flag</th> </tr> </thead> <tr><td><b>None</b></td><td><b>0</b></td></tr> <tr><td>Manual Relief</td><td>1</td></tr> </table>		[M] Manual Relief		Relief Option	Flag	<b>None</b>	<b>0</b>	Manual Relief	1	<table border="1"> <thead> <tr> <th colspan="2">[T] Tank Gasket</th> </tr> <tr> <th>Material</th> <th>Flag</th> </tr> </thead> <tr><td><b>CR (Neoprene)</b></td><td><b>15</b></td></tr> <tr><td>FEPM (AFLAS)</td><td>22A</td></tr> <tr><td>FKM (Viton)</td><td>22V</td></tr> </table>				[T] Tank Gasket		Material	Flag	<b>CR (Neoprene)</b>	<b>15</b>	FEPM (AFLAS)	22A	FKM (Viton)	22V																												
[S] Spring Material																																																															
Material	Flag																																																														
<b>Stainless Steel</b>	<b>0</b>																																																														
Inconel	1																																																														
[M] Manual Relief																																																															
Relief Option	Flag																																																														
<b>None</b>	<b>0</b>																																																														
Manual Relief	1																																																														
[T] Tank Gasket																																																															
Material	Flag																																																														
<b>CR (Neoprene)</b>	<b>15</b>																																																														
FEPM (AFLAS)	22A																																																														
FKM (Viton)	22V																																																														
				<table border="1"> <thead> <tr> <th colspan="2">De-icing System</th> </tr> <tr> <th>Material</th> <th>Flag</th> </tr> </thead> <tr><td><b>D</b></td><td><b>S</b></td></tr> <tr><td><b>A</b></td><td><b>S</b></td></tr> <tr><td><b>M</b></td><td><b>M</b></td></tr> </table>				De-icing System		Material	Flag	<b>D</b>	<b>S</b>	<b>A</b>	<b>S</b>	<b>M</b>	<b>M</b>																																														
De-icing System																																																															
Material	Flag																																																														
<b>D</b>	<b>S</b>																																																														
<b>A</b>	<b>S</b>																																																														
<b>M</b>	<b>M</b>																																																														
				<table border="1"> <thead> <tr> <th colspan="2">Mesh Screen</th> </tr> <tr> <th>Material</th> <th>Flag</th> </tr> </thead> <tr><td><b>1</b></td><td><b>0</b></td></tr> <tr><td><b>2</b></td><td><b>5</b></td></tr> </table>				Mesh Screen		Material	Flag	<b>1</b>	<b>0</b>	<b>2</b>	<b>5</b>																																																
Mesh Screen																																																															
Material	Flag																																																														
<b>1</b>	<b>0</b>																																																														
<b>2</b>	<b>5</b>																																																														

Examples	
Series 4000 Marsh Hawk Venting Gauge Hatch 8" API, 16 ozsi Relief, Viton Seals, Stainless Trim, No Coating, Std Relief w/ Gr 5 Bolt Kit and Neoprene Tank Gasket	<b>MH-016V-000</b> & <b>MH-1057 + MH-1015</b>
Series 4000 Marsh Hawk Venting Gauge Hatch 8" API, 8 ozsi Relief, Kalrez Seals, Inconel Trim, Severe Service Coating, Manual Relief w/ Gr 8 Bolt Kit and Viton Tank Gasket	<b>MH-008K-121</b> & <b>MH-1058 + MH-1022V</b>
Series 4000 Marsh Hawk Venting Gauge Hatch 8" API, 32 ozsi Relief, Viton Seals, Stainless Trim, Anodized Type III, Std Relief w/ 12:1 API Riser, Gr 8 Bolt Kit and Viton Tank Gasket	<b>MH-032V-010</b> & <b>HRP-8P-8P-4A + MH-1058 + MH-1022V</b>

## RELATED PRODUCTS

Series 6000 PVRV



The Series 4000 Marsh Hawk is just one part of tank-age product lines from Hawkeye Industries, that also includes:

### Vapor Control

Series 5000 EPRV

Series 6000 PVRV

### Mechanical Level Indication

Model 1000 Redtail & Model 1500 Roadside Dry Seal Zero Emission Level Gauging Systems

Model 2000 Goshawk Level Transmitter for Dry Seal Zero Emission Level Gauging Systems

